

IP-DU Container / 120 l

120 L

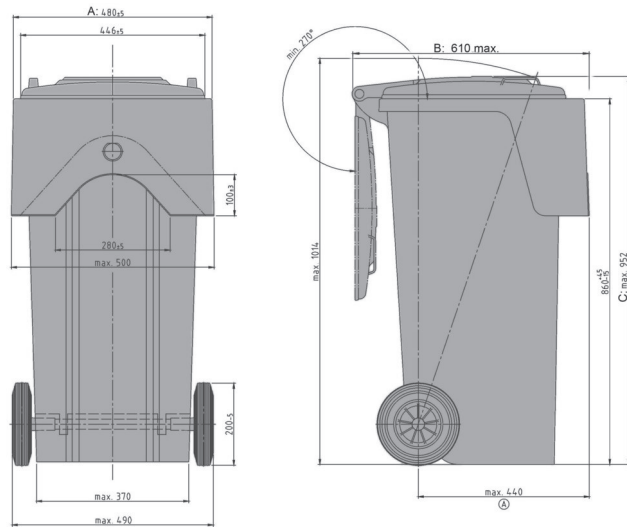

Art.No: IP-DU/CONT/120

Technical Data:			
External dimension L x W x H mm:	A: 480±5	B: 610 max.	C: 952 max.
Volume (l):	120 l		
Material body, material lid:	PE/PE		
Holding capacity (kg)	48 kg		
Available colours:	green, grey, brown, blue, red, yellow		
Characteristics:		Extra equipment / Accessories	
Container corresponds to:	DIN 30760, Directive 2000/14/EG	Automatic lock	
Travelling gear:	External wheel, Ø 200 mm, (DU360: 250mm) rubber tired wheels, wheel axle from tempered galvanized steel	Reflectors	
Receiver:	Diamond receiver		
Prepared for transponder	Yes		
Loading quantities (Pcs Approximate amount):			
On request			
Labeling:			
On the lid, on the body			

*1) All specifications quoted are subject to change. We receive the right to make changes to product design and specification.

*2) Extra equipment, accessories, as well as other colors are available at extra cost and on request

